

CARACTERÍSTICAS:

Fuente de luz:	LED
Potencia:	- 100W/ 120W/ 150W - 200W/ 300W
CRI:	>70Ra
ÁNGULO:	25°/45°/60°/90°
Rango de Tensión:	AC85-265V
Temperatura de color:	2700K-6500K
Lumen:	- 9000-11000lm (100W) - 11000-13000lm (120W) - 13000-17000lm (150W) - 17000-22000lm (200W) - 27000-32000lm (300W)



Campana LED de gran potencia lumínica y amplia cobertura, ideal para espacios amplios y de gran altura. Con más de 50.000 horas de vida útil y reduciendo el consumo energético en comparación con iluminación convencional.

AC85
265V

50/60Hz

Temp.
-20-40°



Más de
50000h



RoHS

Aplicaciones:

- Iluminación de plantas industriales
- Iluminación de comercios
- Iluminación de supermercados
- Iluminación de exterior
- Iluminación de almacén

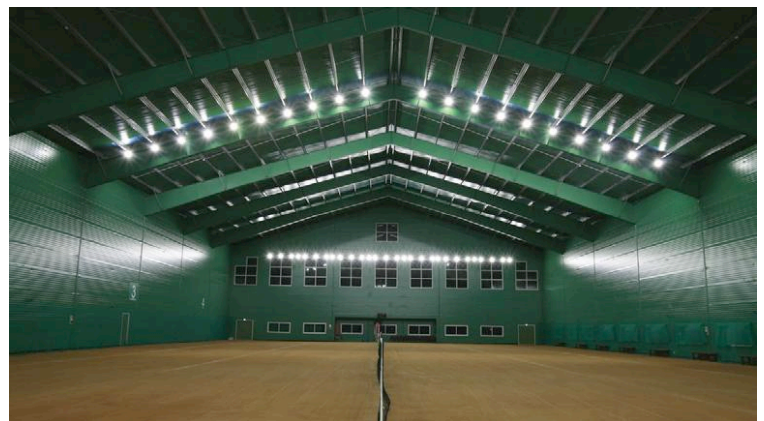

Campanas LED

Diagrama fotométrico:

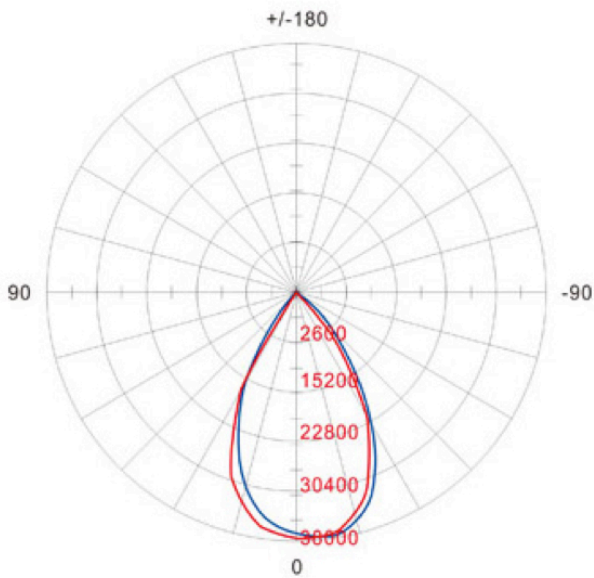

Altura		Diámetro
20.m	139.31 lx	2337.41cm
30.m	61.92 lx	3506.12cm
40.m	34.83 lx	4674.82cm
50.m	22.29 lx	5843.53cm
60.m	15.48 lx	7012.23cm
70.m	11.37 lx	8180.94cm
80.m	8.71 lx	9349.65cm
90.m	6.88 lx	10518.35cm
100.m	5.57 lx	11687.06cm

Dimensiones:

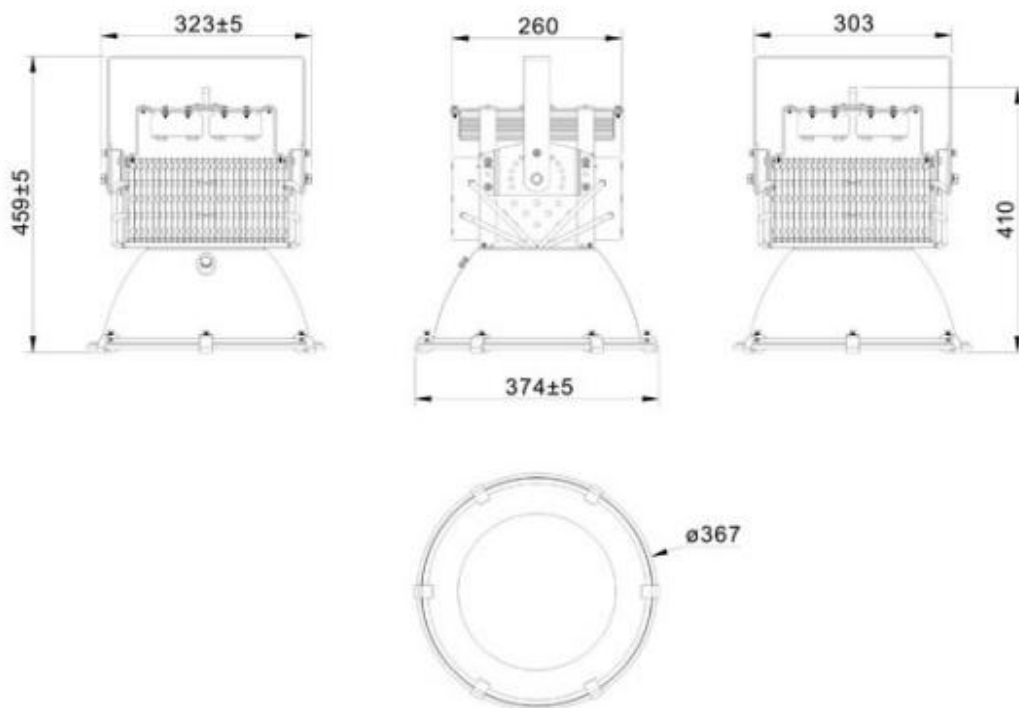

Campanas LED